

# OUTDOOR ELEVATOR







**Quote**                      **Order**





Contact Name: \_\_\_\_\_ Job Name: \_\_\_\_\_













Contact Email: \_\_\_\_\_ Req. Ship Date: \_\_\_\_\_

Initial Drawing Requested                      Drawing Email: \_\_\_\_\_

Approved for production as listed below.

<b>BASICS</b>	<b>OPENINGS</b>	<b>ENCLOSURES</b>	<b>LANDINGS</b>					
	 Single Opening  Pass Through	 Top Only  Top w/ Plexi Side Enclosure None	2 3 Middle Door  LH                      RH					
	<b>Pass Through Only</b>	<b>SAFETY PAN</b>	Customer Provided					
	<table border="1" style="width: 100%; text-align: center;"> <tr> <th style="width: 50%;">Auto Ramp</th> <th style="width: 50%;">Car Gate</th> </tr> <tr> <td>Yes</td> <td>RH</td> </tr> <tr> <td>No</td> <td>LH</td> </tr> </table>	Auto Ramp	Car Gate	Yes	RH	No	LH	Yes No, Hoistway is enclosed
Auto Ramp	Car Gate							
Yes	RH							
No	LH							

<b>TOWER</b>	<b>TOWER HEIGHT</b>	<b>CONFIGURATION</b>	<b>TOWER SUPPORT</b>	<b>TOWER SPLICE</b>	<b>TOWER FASCIA</b>
	18' (standard) 14' (if code requires) 18' - 25'	<i>As viewed from top landing</i>	Standoff  Triangle 	No Yes	Solid Panel  Expanded Panel 
		Tower on Left Tower on Right			

<b>DOORS</b>	<b>LOWER DOOR (42" WIDE)</b>	<b>UPPER GATE</b>																				
	<table border="1" style="width: 100%;"> <tr> <td style="writing-mode: vertical-rl; transform: rotate(180deg);"><b>HEIGHT</b></td> <td>85" - 109" 109" - 133" 133" - 157" 157" - 181" Unsure</td> <td>  </td> <td>RH LH</td> </tr> </table>	<b>HEIGHT</b>	85" - 109" 109" - 133" 133" - 157" 157" - 181" Unsure		RH LH	<table border="1" style="width: 100%;"> <tr> <td>36" (height) Upper Gate</td> <td> <table border="1" style="width: 100%;"> <tr> <th style="width: 50%;">RH</th> <th style="width: 50%;">LH</th> </tr> <tr> <td> </td> <td> </td> </tr> </table> </td> <td>                 Solid                   Picket  </td> <td>                 Swing                   LH                      RH             </td> </tr> <tr> <td>42" (height) Upper Gate</td> <td> <table border="1" style="width: 100%;"> <tr> <th style="width: 50%;">RH</th> <th style="width: 50%;">LH</th> </tr> <tr> <td> </td> <td> </td> </tr> </table> </td> <td></td> <td></td> </tr> </table>	36" (height) Upper Gate	<table border="1" style="width: 100%;"> <tr> <th style="width: 50%;">RH</th> <th style="width: 50%;">LH</th> </tr> <tr> <td> </td> <td> </td> </tr> </table>	RH	LH			Solid  Picket 	Swing  LH                      RH	42" (height) Upper Gate	<table border="1" style="width: 100%;"> <tr> <th style="width: 50%;">RH</th> <th style="width: 50%;">LH</th> </tr> <tr> <td> </td> <td> </td> </tr> </table>	RH	LH				
	<b>HEIGHT</b>	85" - 109" 109" - 133" 133" - 157" 157" - 181" Unsure		RH LH																		
	36" (height) Upper Gate	<table border="1" style="width: 100%;"> <tr> <th style="width: 50%;">RH</th> <th style="width: 50%;">LH</th> </tr> <tr> <td> </td> <td> </td> </tr> </table>	RH	LH			Solid  Picket 	Swing  LH                      RH														
	RH	LH																				
42" (height) Upper Gate	<table border="1" style="width: 100%;"> <tr> <th style="width: 50%;">RH</th> <th style="width: 50%;">LH</th> </tr> <tr> <td> </td> <td> </td> </tr> </table>	RH	LH																			
RH	LH																					

<b>POWER</b>	<b>SUPPLY VOLTAGE</b>	<b>WIRE LENGTHS</b>		<b>FINISH</b>	<b>FINISH</b>	
	110 VAC (Non GFI Outlet) Battery Lowering	Door/Gate Wire	Standard		Custom	Mill Finish Powder Coat Matte White Powder Coat Matte Grey
		Travel Cable	20'		_____	
		Motor Wire	22'	_____		

<b>SHIPPING</b>	<b>SHIPPING</b>	<b>ADDITIONAL INFORMATION</b>
	Pick Up Delivery (if available) Shipping By Others	

PLEASE FILL IN THE **TRAVEL DISTANCE** & **HEIGHT TO LOWEST EAVE** VALUES BELOW

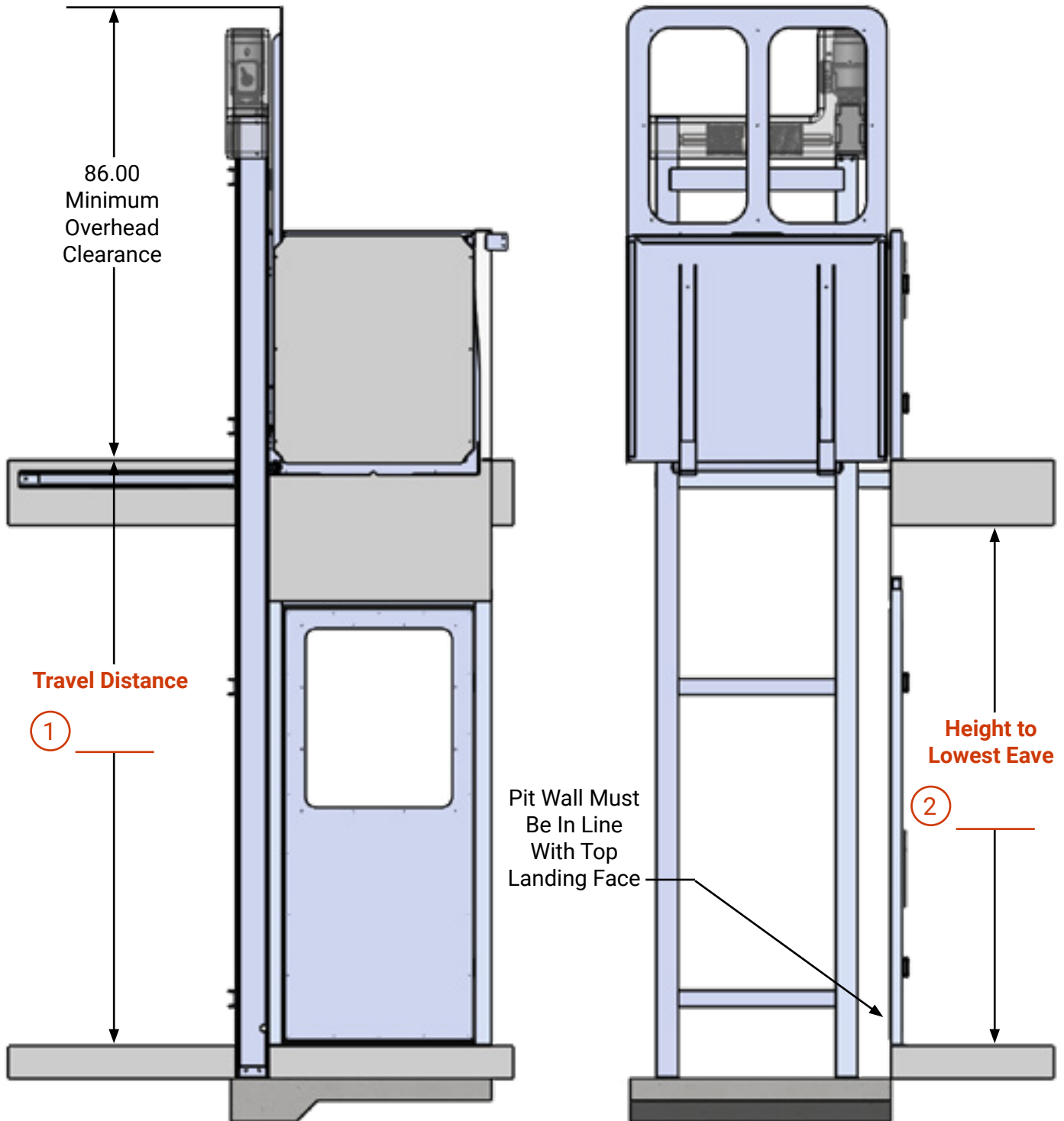

**PIT OPTIONS**

**Recessed 6" Pit**

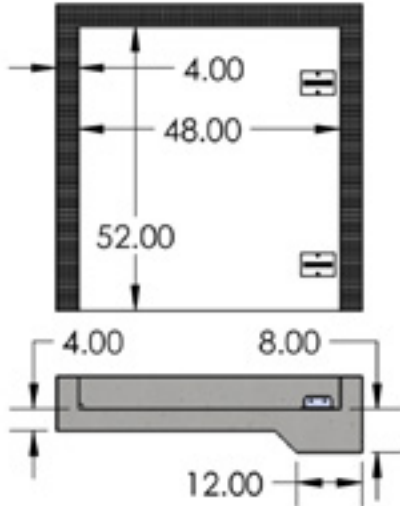

**Recessed 6" Slab**

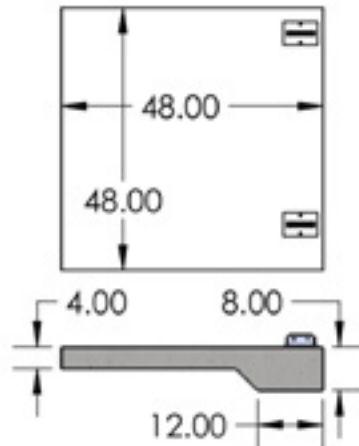

**Recessed 6" Footer**

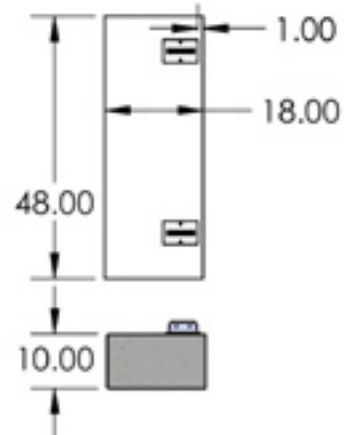

**No Pit / 6" Fixed Ramp**

**No Pit / 6" Fixed Ramp by Others**

Gate Opening from Pit Edge	A
LH Swing	4.25
RH Swing	6.25

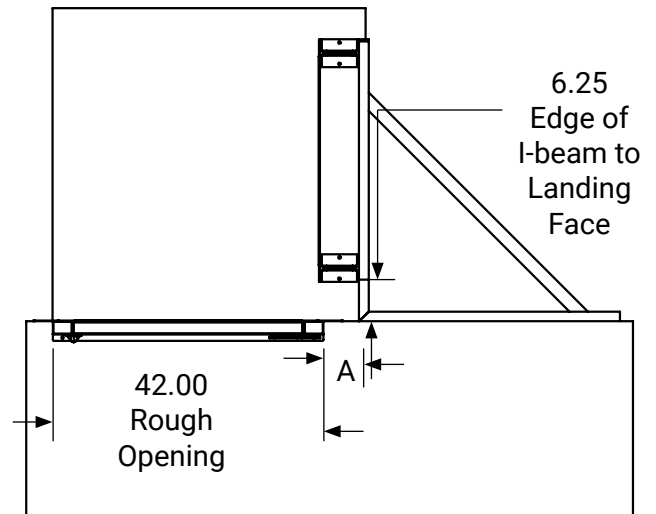

**PIT REQUIREMENTS**

- » All concrete to be reinforced with #3 rebar @ slab/footer mid-depth.
- » 6" depression recommended from bottom floor to pit/slab/footer.
- » Dimensions must meet or exceed minimum requirements listed above.

**ELECTRICAL REQUIREMENTS**

CONTROLLER COMES EQUIPPED WITH A 120VAC PLUG/PIGTAIL.  
 REQUIRES A DEDICATED CIRCUIT, 120VAC, 20AMP OUTLET WITHIN SIGHT OF THE LIFT.  
 FOR JURISDICTIONS WHICH REQUIRE THE CONTROLLER TO BE HARDWIRED,  
 CUT CORD END AND HARD WIRE INTO APPROPRIATE DISCONNECTING MEANS.  
 CORD MAY ALSO BE REMOVED AND REPLACED WITH APPROPRIATE WIRE SUPPLIED BY OTHERS.